

8 7 6 5 4 3 2 1

D D

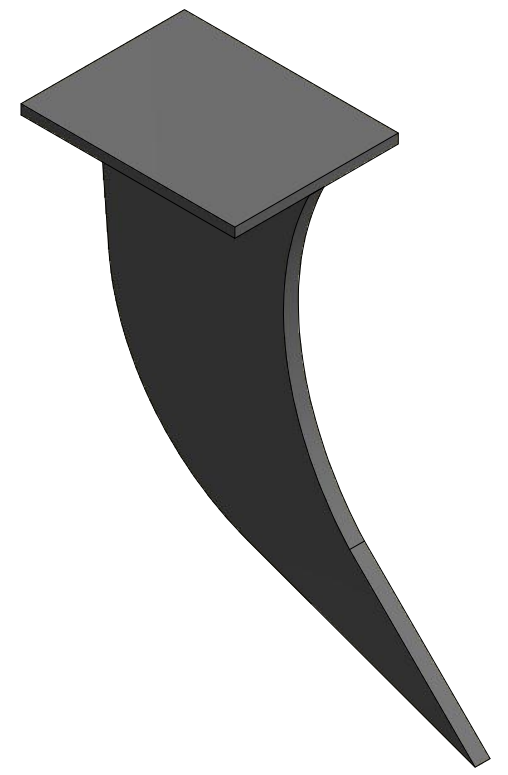
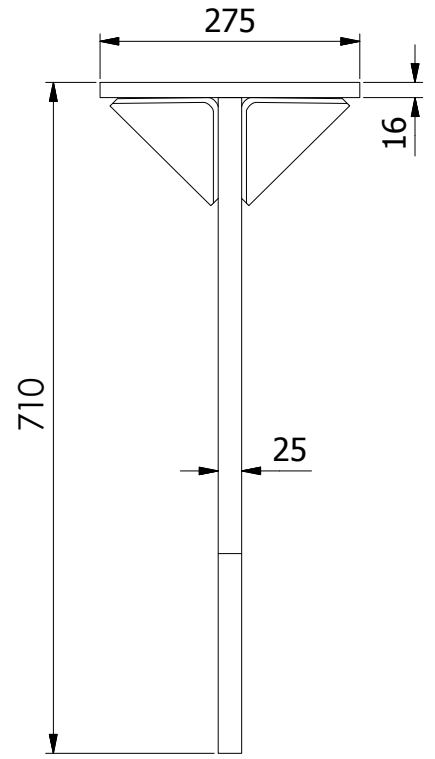
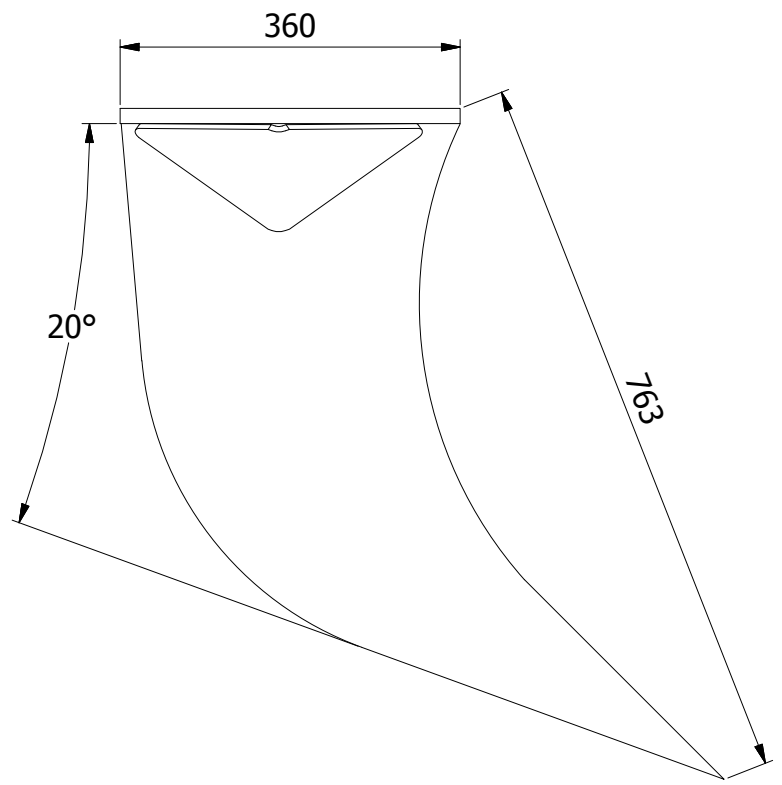

C C

B B

MATERIAL SPECIFICATION	
ST52.3	
EN8D	
HB 400	
HB 450	
CASALLOY STEEL	

SCANBOLT®	
DESCRIPTION	RIPPER PLATE TYPE
MACHINE CLASS	1.5 - 3.0 TON
WEIGHT	54.4 Kg
HEAPED CAPACITY	N/A

8 7 6 5 4 3 2 1

A A